

VERSA STAR™



DLX4-HK-**

4-LED Single Wide w/Cig Plug



DLX4-HK-1-**

4-LED Single Wide w/Hardwire



DLX4-HK2-**

4-LED Double Wide w/Cig Plug



DLX4-HK2-1-**

4-LED Double Wide w/Hardwire



DLX6-HK-**

6-LED Single Wide w/Cig Plug



DLX6-HK-1-**

6-LED Single Wide w/Hardwire



DLX6-HK2-**

6-LED Double Wide w/Cig Plug



DLX6-HK2-1-**

6-LED Double Wide w/Hardwire



STAR

Safety Technologies by *Crote*

455 Rochester Street Avon, NY 14414
585-226-9500 (F) 888-478-2797
www.StarSafetyTechnologies.com

PLIT457 REV. C 2/22/24

Installation Notes

IMPORTANT: Please read all of the following instructions before installing your new light. Failure to follow these safety precautions may result in damage to your light or vehicle and may result in serious injury or death to you and your passengers.

- The installer must have a firm knowledge of basic electricity, vehicle electrical systems, and emergency equipment.
- If you need to drill any holes when installing this light, please take care to check that BOTH SIDES of your drilling surface are clear from obstructions.
- Choose a mounting location away from any air bag deployment areas.
- Controls should be placed within convenient reach of the driver.
- Use only soap and water when cleaning this product. Use of other chemicals may discolor the lens and/or housing, thus diminishing the output of the light. Lenses that have become discolored should be replaced immediately!
- DO NOT use a pressure washer to clean this light. Use of a pressure washer may damage the light and WILL VOID THE WARRANTY.



This light uses high-intensity lights. DO NOT stare directly into the light while it is on, as momentary blindness and/or permanent eye damage may occur.

Please Note: These instructions are provided as a general guideline only. **Some vehicles may require special mounting, wiring, and/or weather-sealing. This is the sole responsibility of the installer.** Star Safety Technologies assumes no responsibility for the integrity of the installation for this or any of its products.

NOTICE

Due to continuous product improvements, we must reserve the right to change any specifications and information, contained in this manual at any time without notice. Star Safety Technologies, Inc. makes no warranty of any kind with regard to this manual, including, but not limited to, the implied warranties of merchantability and fitness for a particular purpose. Star shall not be liable for errors contained herein or for incidental or consequential damages in connection with the furnishing, performance, or use of this manual.

VERSA STAR™

Mounting

1. The Versa Star™ can be mounted in the front windshield of a vehicle, in the rear window, on the rear deck, or directed out the side window. All of the mounts will require you to attach the mounting bracket to the light.

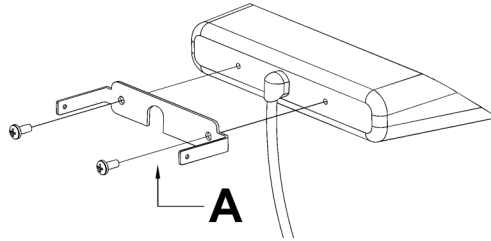

2. Based on where you are going to mount the light and where you will run the cord, determine which direction you will mount the bracket to your light (pivot point at the top or at the bottom). Attach Part A of the mounting bracket, facing the direction you have selected, to the light by using two Phillips head screws.

CAUTION: Take extreme caution not to over tighten the screws!!! Over tightening of the screws can strip the holes and result in a faulty mount.

3. Once Part A is secured to the light, use two Philips head screws, two flat washers, and two tooth washers to attach Part B of the mounting bracket to Part A. (See the diagram below for proper installation of the washers.)

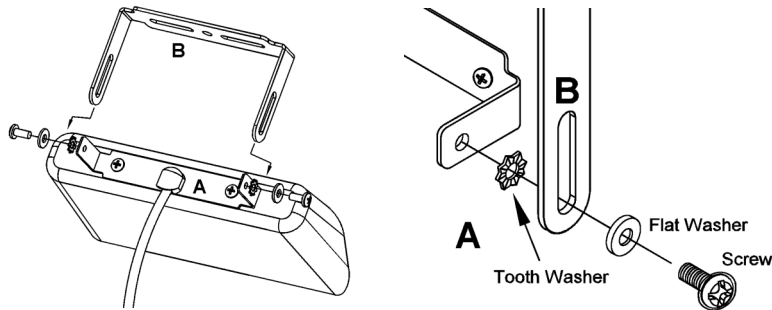

CAUTION: Take extreme caution not to over tighten the screws!!! Over tightening of the screws can strip the holes and result in a faulty mount.

4. If you are mounting the light directly to the rear deck, dash, or other suitable surface, you may use appropriate fasteners (not supplied) to attach the bracket to your mounting surface. Skip to step 10.

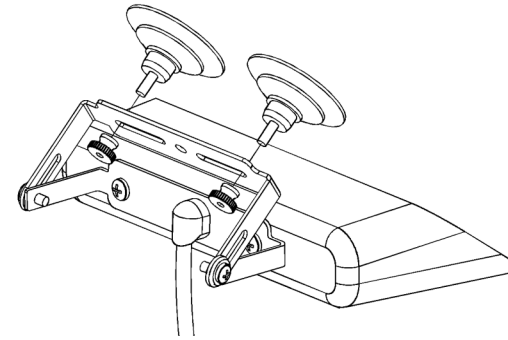
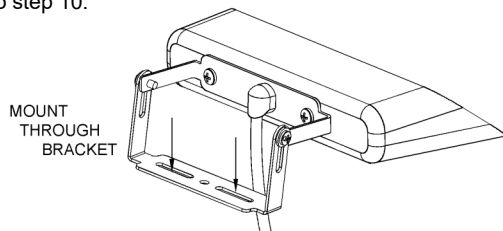

5. If you are utilizing the suction cup mount, attach the DL15-CUP suction cups to the mounting bracket. Then mount the light in the desired location and skip to step 10.

CAUTION:
Take extreme caution not to over tighten the suction cups!!! Over tightening of the screws can strip the holes or puncture the inside of the cup and result in a faulty mount.

274-ULB9MMC

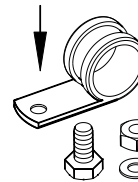

6. If you are using the 274-ULB9MMC to mount your light to your rear view mirror, it is the sole responsibility of the installer to ensure that the rear view mirror mount can support the light you are installing.
7. Remove the 274-ULB9MMC clamp, nut, bolt, and washer from the hardware kit.

8. Place the 274-ULB9MMC clamp around the mirror stem.

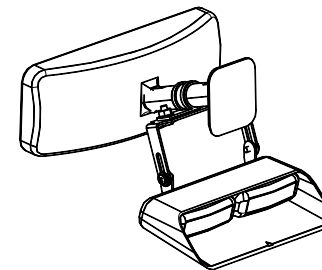
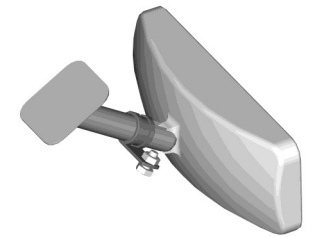

9. Attach the clamp to the ULB9-BKT with the washer, nut and bolt, securing your light to the rear view mirror.

10. Once the light is secured, route your cord such that it does not interfere with the vision of the driver or the operation of the steering wheel, gear shifter, and/or any airbags.

Wiring Instructions (Hard Wired Versions Only)



When wiring your lights, YOU MUST take the following precautions to eliminate Electromagnetic Interference (EMI).

- The LED modules and the radio (or other sources of EMI) should be kept as far away from each other as possible.
- Separate the radio wires and the LED wires:
 - ▲ The radio antenna wire should make a right angle from the back of the radio and run down one side of the vehicle.
 - ▲ The LED wires should make a right angle out of the back of the switchbox and exit in the opposite direction of the antenna wire and/or radio power wires.
- Any excess wires should be cut short.
- The Ground wire, Power wire, and Synchronization wire should be bound tightly together as they run from light to light, through your switchbox, and finally to the battery.
- Do not ground each unit independently to the chassis. Run the ground for each unit as shown below in a "bus" like structure, to the negative terminal on the battery.
- The total distance between the two farthest units should be no more than 40 feet.

BEFORE installing your lights and running your wires, please review the diagram below showing an example of how the wires should be run.

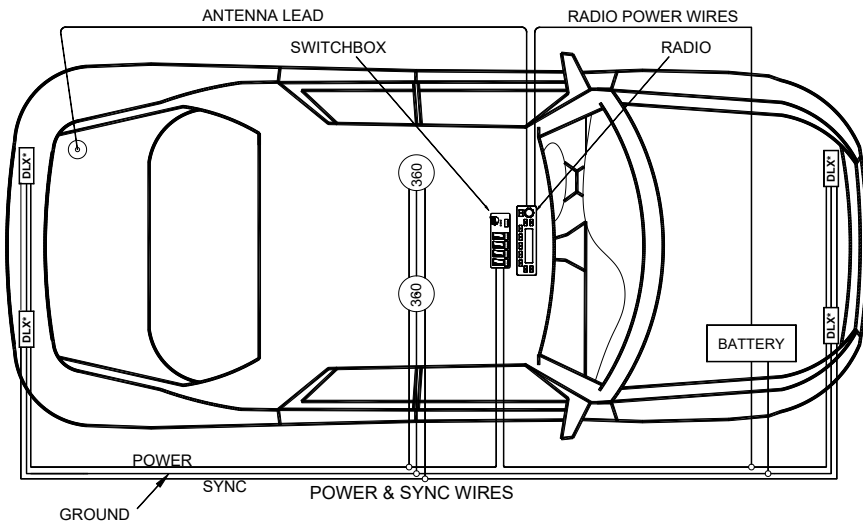

Please Note: When running your wires, the Black wire (battery -), the Red wire (battery +), and the White wire (synchronization) should be bound tightly together as they run from light to light, through your switchbox, and finally to the battery. See the diagram on the previous page.

(Wiring cont'd)

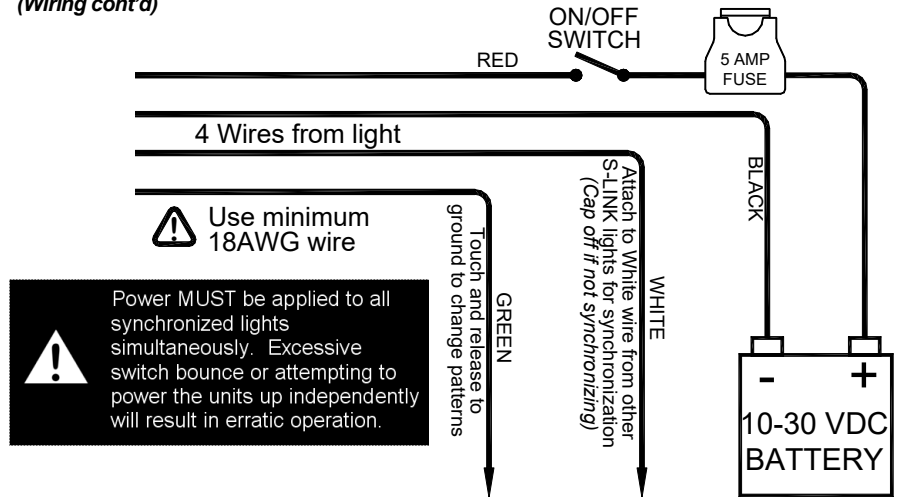

If you will be synchronizing two or more lights, leave the white wire disconnected for now. Connect the white wires from both units together **ONLY AFTER PROGRAMMING** them for the same pattern (see Pattern Programming).

Pattern Programming

1. **Decide if you want an Alternating Pattern or a Simultaneous Pattern.** Each light has 10 different Pattern Types you can cycle through in either an alternating mode or a simultaneous mode. There is also an additional "Steady Burn Mode". (See Pattern List on next page)

If you are running in an alternating mode (patterns 1-10), the two halves will alternate the pattern back and forth. If you are running in a simultaneous mode (patterns 11-20), the two halves will display the same pattern at the same time. The diagram below illustrates the outputs of the different patterns.

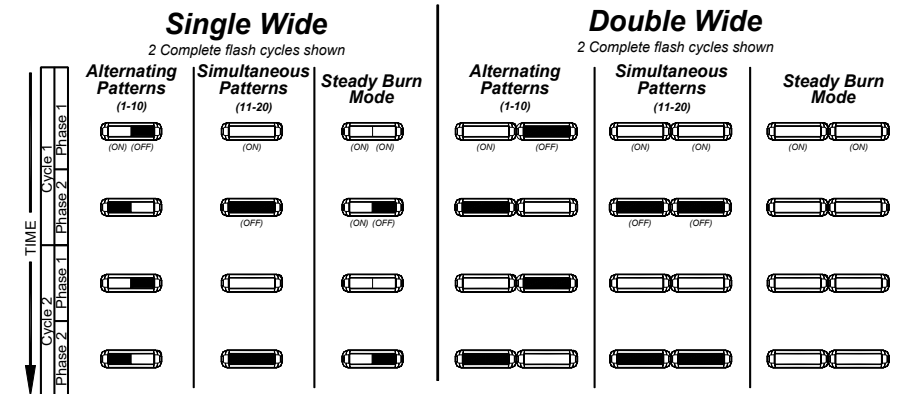

PLEASE NOTE: The Steady Burn Mode for the double wide unit **does NOT** have the option to have one side Steady Burn and the other side flashing. If you need this option, the light must be custom ordered and preprogrammed at the factory.

(Pattern Programming cont'd)



2. Depending upon your model, the pattern select button on the cig plug, or the **green wire** on hard-wired models is used to program the desired flash pattern.

3. These lights are shipped programmed for Pattern 3 (Pattern Type M - Alternating Tripleflash). If you wish to select a different Pattern Type, proceed below:

- A. Select the pattern you would like from the list below or on the following page.
- B. Power up the light.
- C. Use the programming shortcuts below to jump directly to the pattern you want, or to the closest pattern before the pattern you want.

Programming Shortcuts

<u>Touch the Green Wire to Ground For:</u>	<u>Unit Blinks</u>	<u>Jumps To</u>
3 seconds	1 time	Pattern 1
6 seconds	2 times	Pattern 6
9 seconds	3 times	Pattern 11
12 seconds	4 times	Pattern 16
15 seconds	5 times	Split/Steady Side Select ‡
18 seconds	6 times	Steady Burn Pattern

‡ = Applies only to single wide units in Split Mode

D. Touch the **green wire** to ground (or press the Pattern Select Button) to cycle through Patterns 1-20.

PLEASE NOTE: When scrolling through patterns, the pattern cycle **does NOT** include the Steady Burn mode. (see section below)

4. Once you have found the desired pattern, if applicable, tape off or place a wirenut over the end of the green wire to prevent it from coming into contact with ground again.



(Pattern Programming cont'd)

Pattern List

Flash Pattern #	Pattern Type	S-LINK SYSTEM Pattern Description	CPS	Pattern Defaults	Light Blinks	
1	K	Alternating Patterns	Flicker †	1.0	3Sec	1 time
2	L		Fast Doubleflash	3.3		
3	M		Tripleflash	2.5		
4	N		PSU Flicker	0.7		
5	O		PSU Random	0.6		
6	F		Quadflash †	1.0	6Sec	2 times
7	G		Quadflash w/Post-Pop †	1.0		
8	H		Singleflash †	1.0		
9	I		Double flash †	1.0		
10	J		Variable AKA Delta-Omega	0.3		
11	K	Simultaneous Patterns	Flicker †	1.0	9Sec	3 times
12	L		Fast Doubleflash	3.3		
13	M		Tripleflash	2.5		
14	N		PSU Flicker	0.7		
15	O		PSU Random	0.6		
16	F		Quadflash †	1.0	12Sec	4 times
17	G		Quadflash w/Post-Pop †	1.0		
18	H		Singleflash †	1.0		
19	I		Doubleflash †	1.0		
20	J		Variable AKA Delta-Omega	0.3		
NA		Steady Burn	NA	18Sec	6 times	

† - Approved patterns for SAE J845 and California Title 13

To set the light to one of the **Pattern Defaults**, hold green wire to GND for the appropriate time as stated in pattern list. Patterns 1, 6, 11, 16 and Steady are defaults.

To increment through the pattern list, momentarily connect Green wire to GND and release.

Note: Pattern Type letters are common to all **S-LINK SYSTEM** products. Any lights programmed for the same Pattern Type letter can be synchronized together.

Steady Burn Mode

- Power the light up.
- Press and hold the Pattern Select Button or touch and hold the Pattern Select wire (Green) to Ground until the light blinks six times (approximately 18 seconds), then release it. The light should be in Steady Burn mode.
- **FOR SINGLE-WIDE UNITS ONLY:** Once the unit is in Steady burn mode, repeating this will toggle the light between 1/2-light Steady Mode and Full-Light Steady Mode.
- **FOR SINGLE-WIDE UNITS ONLY:** In 1/2-Light Steady Mode, to flip-flop the steady side and the flashing sides, press and hold the Pattern Select Button or hold the Green wire to Ground until the light flashes 5 times (approximately 15 seconds) and then release it.
- **FOR SINGLE-WIDE UNITS ONLY:** In 1/2-Light Steady Mode, to change the pattern on the flashing side, press and release the Pattern Select Button or touch and release the Green wire to Ground.
- To exit Steady Burn Mode, place the light into Full-Light Steady Mode (see above), then press the Pattern Select Button or touch and release the Green wire to Ground.

Synchronization of Multiple Lights (Hard Wired Versions Only)

You can synchronize up to six lights (3 double wide units) with **SPUNK SYSTEM** compatibility.

If you have multiple hard-wired lights and would like to synchronize them to flash with one another, please review this section.

Synchronization options are shown below.

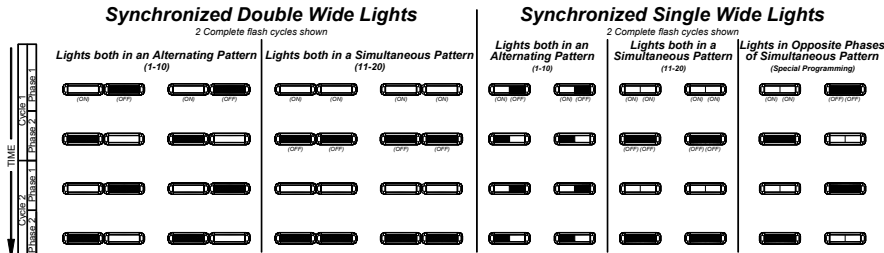

! If you will be synchronizing two or more units together, leave the white wires disconnected until programming for each has been completed. Connect the white wires from the units together **ONLY AFTER PROGRAMMING** them all for the same Pattern Type (Phase MAY differ).

- After programming the first light (as described on the previous page) program the second light. Keep in mind the following:
 - ALL SYNCHRONIZED LIGHTS MUST HAVE THE SAME PATTERN TYPE!!!**
 - Simultaneous Patterns 11-20 are in Phase 2 (certain other **SPUNK SYSTEM** lights can be programmed for different phases).
 - Lights or sides set for the SAME phase flash together (simultaneous), lights with DIFFERENT phases flash opposite one another (alternate).
 - Use the Pattern Shortcuts listed on the previous page to simplify programming.
- Once you have found the desired pattern on the second light, tape off or place a wirenut over the end of the green wire to prevent it from coming into contact with ground again.
- Repeat Steps 1-2 above for each additional head you wish to synchronize.
- After** you have the correct patterns programmed in for **ALL** of the lights you wish to synchronize, turn all of the lights off and connect the white wires from all units together.
- Power all of the lights up **at the exact same time** to verify they are flashing in the desired pattern.

Special Programming for Alternating Two DLX4-HK1 or DLX6-HK1 Lights

By default, when synchronizing two single heads (DLX4-HK1 or DLX6-HK1) set for simultaneous mode, they can only be synchronized to flash on at the same time. If you would like to have them alternate (see diagram to right), you will need to change the programming mode by using the following steps:

- Connect the **Red** and **White** wires from one of the lights to **+12VDC**.
- Connect the **Black** wire to **ground**.
- Touch the **Green** wire to **ground** until the light flashes once (approximately 3 seconds).
- Remove the **Green** wire from **ground** and wait 1 second.
- Remove the **White** wire from power.
- Repeat Steps 1-5 above for each additional head you wish to synchronize.
- The lights will now be in "Standard DLX4 Mode" and will only flash both halves of each light together (simultaneous).
- Activate one light by connecting the **Red** to **+12VDC** and the **Black** to **ground**.
- Touch and release the **Green** wire to **ground** to cycle through the patterns listed below setting the head to your desired **Phase 1** pattern (patterns 1-10).
- Repeat steps 8-9 to set the other head for the same **Pattern Type**, but in **Phase 2**.
- Remove power and connect the white wires together. The heads should now alternate.

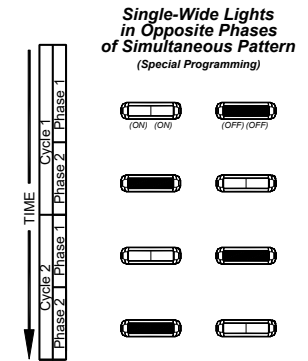

Special Patterns for Reprogrammed DLX4-HK1 and DLX6-HK1 Lights

Flash Pattern #	Pattern Type	Phase	SPUNK SYSTEM Pattern Description	CPS	Pattern Defaults
1	K	1	Flicker †	1.0	3Sec
2	L		Fast Doubleflash	3.3	
3	M		Tripleflash	2.5	
4	N		PSU Flicker	0.7	
5	O		PSU Random	0.6	
6	F		Quadflash †	1.0	6Sec
7	G		Quadflash w/Post-Pop †	1.0	
8	H		Singleflash †	1.0	
9	I		Doubleflash †	1.0	
10	J		Variable AKA Delta-Omega	0.3	
11	K	2	Flicker †	1.0	9Sec
12	L		Fast Doubleflash	3.3	
13	M		Tripleflash	2.5	
14	N		PSU Flicker	0.7	
15	O		PSU Random	0.6	
16	F		Quadflash †	1.0	12Sec
17	G		Quadflash w/Post-Pop †	1.0	
18	H		Singleflash †	1.0	
19	I		Double flash †	1.0	
20	J		Variable AKA Delta-Omega	0.3	
NA		N/A	Steady	NA	18Sec

† - Approved patterns for SAE J845 and California Title 13

To set the light to one of the **Pattern Defaults**, hold green wire to GND for the appropriate time as stated in pattern list. Patterns 1, 6, 11, 16 and Steady are defaults.

The revert to original mode, repeat Steps 1-5 holding the **Green** wire to ground for 3 flashes at Step 3.

Troubleshooting Guide

These lights use state-of-the-art Light Emitting Diode (LED) technology. This light is comprised of ultra-bright LEDs that are operated in a multiplexed mode to efficiently produce light output with lifetimes up to 100,000 hours. Under normal circumstances, you will not need to replace any LEDs in this light. If any of the LEDs in your light do fail, please contact Star for arrangements to have them repaired.

NOTE: Most failures can be traced to wiring and battery problems. Check "quick-connects" and wiring to insure that correct voltage/polarity is reaching the light.

Symptom	Possible Cause	Check	
No Light	Power or polarity	A nominal +10-30VDC should be reaching the red wire Is power hooked up backwards? Positive ground vehicle? (Unit designed for negative ground vehicles)	
	Inline fuse blown	Is an external fuse or circuit breaker used?	
	Bad ground	Are the negative leads connected to a good ground?	
	White wire shorted	White wire should only be connected to other white wires. Power applied to it will prevent the light from flashing	
	Green wire shorted	Green wire should remain unconnected. If grounded, light will cease to function.	
	Shorts		Do wires run thru bare metal holes that have damaged them?
			Are the wires pinched or broken anywhere?
LED's appear dim	Low battery voltage	Measure while lights are on. Voltage below 10V will result in reduced LED output.	
	Power wires are too small/long	Measure while lights are on. Voltage below 10V will result in reduced LED output.	
Erratic operation	Bad routing of wires	Do wires run thru bare metal holes that have damaged them? Are the power or control wires close to: Strobe power supplies, tubes, cables, police/two-way radios or alternator?	
	Interference from other accessories?	Try running with the car and all other accessories off	
	Synchronization issues	Is one of the lights that are synched together hooked up incorrectly? Are any white wires shorted to power?	

Service

LED FIVE YEAR LIMITED WARRANTY

Star Safety Technologies warrants this LED light against factory defects in material and workmanship for five years after the date of manufacture. The owner will be responsible for returning to the Service Center any defective item(s) with the transportation costs prepaid. The manufacturer will, without charge, repair or replace *at its option*, products, or part(s), which its inspection determines to be defective. Repaired or replacement item(s) will be returned to the purchaser with transportation costs prepaid from the service point. A copy of the purchaser's receipt must be returned with the defective item(s) in order to qualify for the warranty coverage. Exclusions from this warranty include, but are not limited to, domes, and/or the finish. This warranty shall not apply to any light, which has been altered, such that in the manufacturer's judgment, the performance or reliability has been affected, or if any damage has resulted from abnormal use or service.

There are no warranties expressed or implied (including any warranty of merchantability or fitness), which extend this warranty period. **The loss of use of the product, loss of time, inconvenience, commercial loss or consequential damages, including costs of any labor, are not covered.** Star reserves the right to change the design of the product without assuming any obligation to modify any product previously manufactured.

This warranty gives you specific legal rights. You might also have additional rights that may vary from state to state. Some states do not allow limitations on how long an implied warranty lasts. Some states do not allow the exclusion or limitation of incidental or consequential damages. Therefore, the above limitation(s) or exclusion(s) may not apply to you.

If you have any questions concerning this or any other product, please contact our **Customer Service Department** at (585) 226-9787.

If a product must be returned for any reason, please contact our Customer Service Department to obtain a Returned Materials Authorization number (RMA #) before you ship the product back. Please write the RMA # clearly on the package near the mailing label.

NOTICE

Due to continuous product improvements, we must reserve the right to change any specifications and information, contained in this manual at any time without notice. Star Safety Technologies, Inc. makes no warranty of any kind with regard to this manual, including, but not limited to, the implied warranties of merchantability and fitness for a particular purpose. Star shall not be liable for errors contained herein or for incidental or consequential damages in connection with the furnishing, performance, or use of this manual.

STAR
Safety Technologies by *Crata*

455 Rochester Street Avon, NY 14414
585-226-9500 (F) 888-478-2797
www.StarSafetyTechnologies.com